

SLOB 72.5-170 kV Vertical-break disconnectors



HV Switching

We know how

Our range of vertical-break disconnectors is designed to ensure the best performances and reliability, which are the result of our 70-year old experience. Over 100,000 disconnectors installed in more than 100 countries worldwide are the guarantee of best-buys.



The SLOB vertical-break disconnector

The SLOB disconnector is composed of three poles, operated simultaneously either by a single operating mechanism and mechanical linkages between the poles or by one mechanism for each pole.

Since the arms move on vertical planes, the SLOB allows to minimize the phase-to-phase distance, thus allowing space saving in substation design.

The insulators, directly bolted on the base frame, ensure a good withstand to terminal loads and comply with either IEC or ANSI standards. Special heights and creepage distances are also available upon request.

To adapt to various layout of substations, the poles can be erected traditionally (horizontally) or wall-mounted, and even upside down.

Like all our models, the SLOB meets the latest international standards (IEC, ANSI) and it can also be customised according to clients' particular specifications

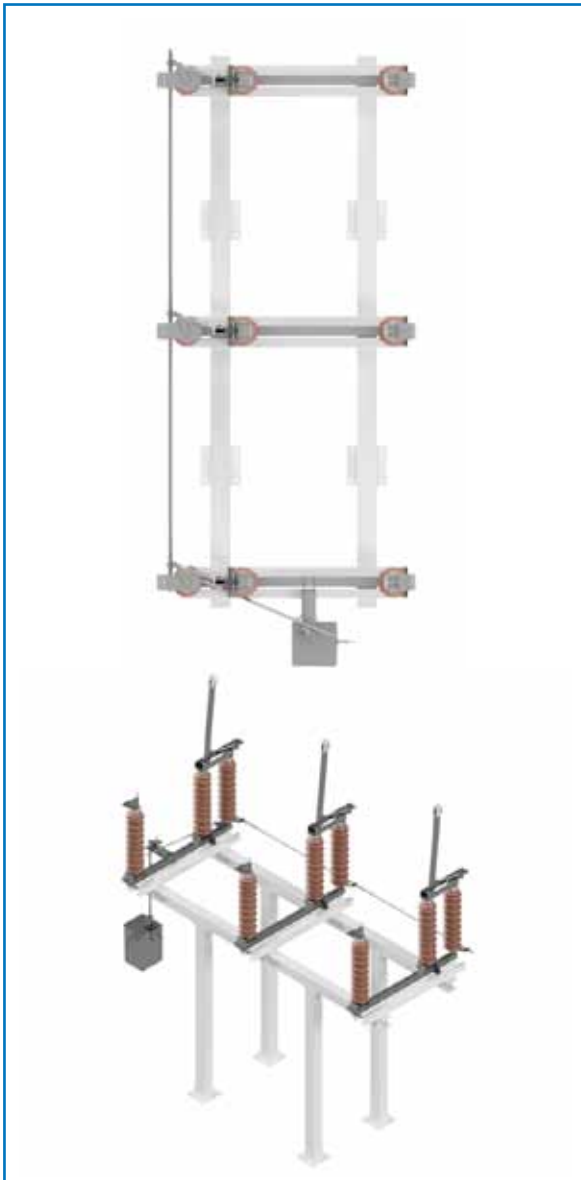

Earthing switch

Integrated earthing blades are available for mounting on each pole, with the same short-time current withstand capability as the main blades.

The earthing switch is actuated by the same types of operating mechanisms as the disconnector, either manually or electrically, either single- or 3-pole. It can be electrically and/or mechanically interlocked with the main switch.

Construction features

The main circuit of each pole consists of a mobile arm and a fixed contact.

The moving arm is made of an aluminium alloy tube with copper fingers bolted at its end; number and dimensions of fingers depend on the rated current, while the contact pressure is assured by stainless steel springs; the moving arm is hinged, at the other end, to an aluminium alloy welded support, which includes one of the two HV terminals of the main circuit; flexible aluminium straps ensure the connection between the moving arm and its support.

The fixed contact consists of an aluminium alloy welded support, which includes the other HV terminal; a copper flat bar, suitably shaped for the correct engagement with the moving contact, is bolted to the support.

Copper contacts are silver plated, with silver thickness depending on the rated current; they are self-cleaning and are suitably designed for withstanding considerable short-circuit stresses.

The base frame of each pole, which is provided with a rotary support, is made of hot-dip galvanised steel; its bearings are sealed and guaranteed to ensure maintenance-free operation for the whole life of the equipment.

The transmission system consists of a set of shafts, rods and levers, made of hot-dip galvanised steel and suitably linked to each other to transmit the power from the operating mechanism to the rotary supports of base frames.

The whole design and manufacturing process is ruled by ISO 9001 certified procedures, to guarantee perfect performance reproducibility from type-testing to series production.



Operating principle

The base frame supports two post insulators **1** and one rotating insulating rod **2** (driving insulator) which allows to transfer the motion of the operating mechanism to the main circuit.

In open position the moving arm **3** is about 5° beyond the vertical.

The rotation of the insulating rod is transmitted to the moving arm by a crank-lever mechanism **4**, which makes the arm rotate in the vertical plan until the moving contact **5** (female) inserts into the fixed one **6** (male) and the fully closed position is reached.

When necessary for a smooth and low power-demanding motion, the weight of moving arm is balanced by a spring.

The HV terminals **7** as shown in the next page figure; customised terminals are also available upon request.

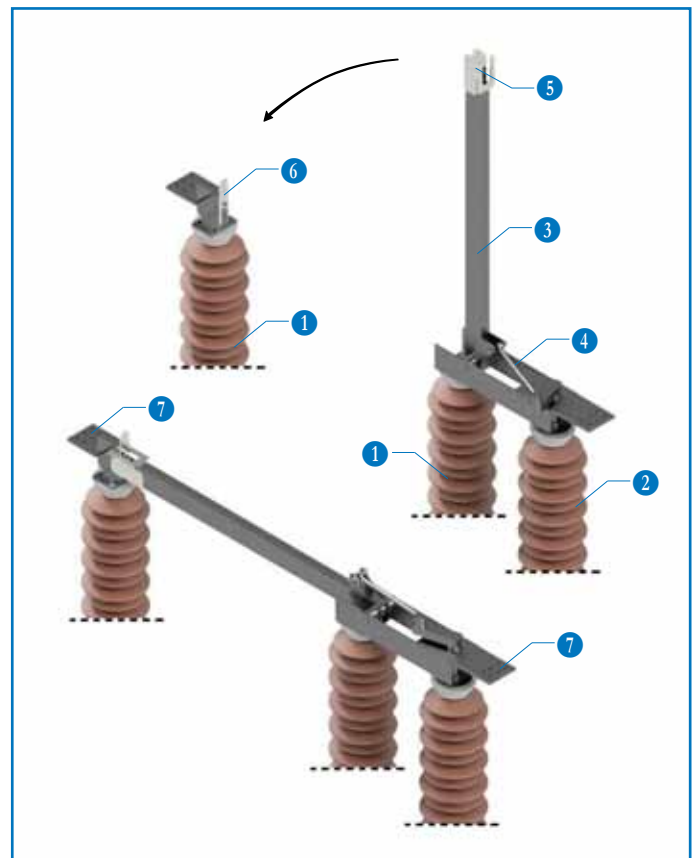

Ratings and dimensions

The values in the table refer to IEC standards, unless explicit reference to ANSI is made; for missing ANSI ratings, refer to C37.32

Rated voltage		U_r (kV)	72.5	100	123	145	170
Rated power-frequency withstand voltage	TE	U_d (kV)	140	185	230	275	325
	AID	U_d (kV)	160	240	265	315	375
Rated lightning impulse withstand voltage	TE	U_p (kV _p)	325 (IEC) 350 (ANSI)	450	550	650	750
	AID	U_p (kV _p)	375	520	630	750	860

TE: To Earth

AID: Across the Isolating Distance

Rated continuous current	I_r (A)	up to 2500 IEC / ANSI (depending on rated voltage)
Rated short-time withstand current	I_k (kA)	up to 40 / 3s (depending on rated current)
Rated peak withstand current	I_p (kA _p)	up to 108 (depending on rated current)

Dimensions (mm)	A		1000	1200	1500	1600	1800
B	IEC		770	1020	1220	1500	1700
	ANSI		762	-	1143	1372	1575
C	IEC		1130	1380	1580	1860	2060
	ANSI		1122	-	1503	1732	1935
D	-		2195	2645	3145	3525	3925
E	-		1200	1400	1700	1800	2000

Reliability and maintenance

Due to lifetime greased (or self-lubricated) hinges and to self-wiping contacts, the maintenance of the SLOB is ensured by its motion.

The use of corrosion-free (or coated) materials for all components ensures exceptional reliability for many years of service.

The mechanical endurance performance exceeds IEC standard requirements.

Optional devices

Upon request, the disconnecter can be equipped with a bus-transfer current switching device, compliant with IEC 62271-102.

The integrated earthing switch can also be fitted with an optional induced current switching device, compliant with IEC 62271-102.

For operation under severe ice conditions (up to 20 mm), ice shields are available for protection of the equipment (where needed), compliant with IEC 62271-102.

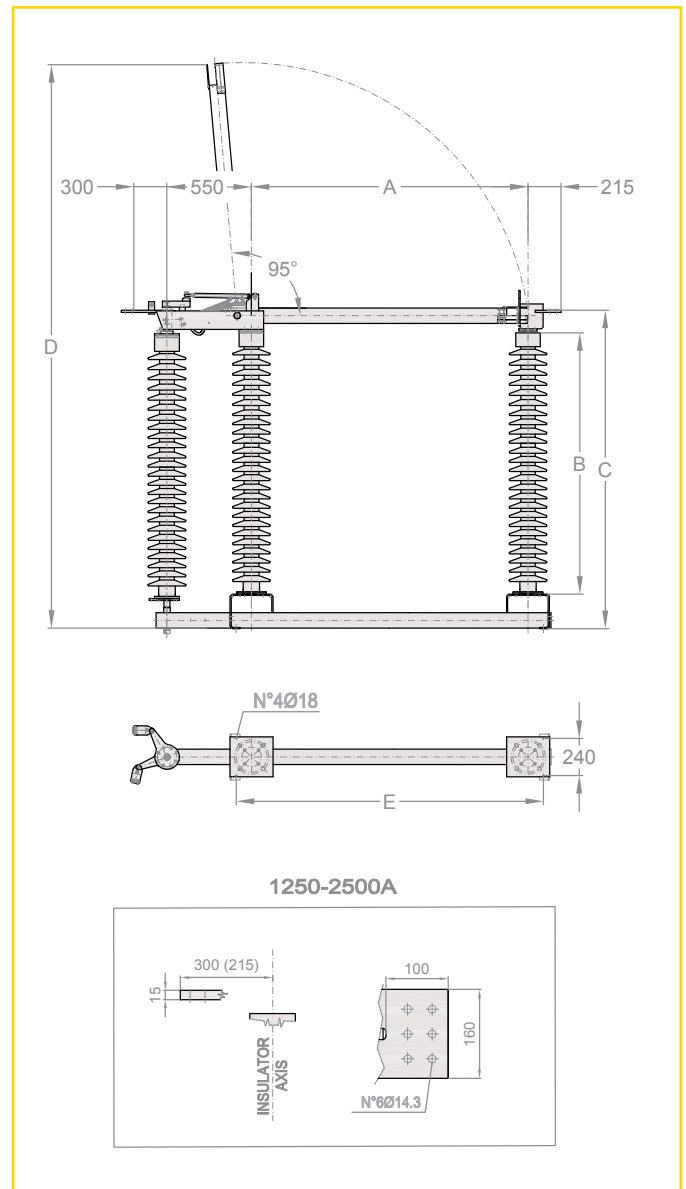

SLOB-en-C/E - 09/2020 - Due to product and standards evolution, characteristics and dimensions shown might change.

COELME

Via G. Galilei, 1/2 - 30036 Santa Maria di Sala (VE) - Italia
Tel.: +39 041 486022 - Fax: +39 041 486909
E-Mail: contact@coelme-egic.com, www.coelme-egic.com
f @ in

EGIC

60b, rue L. et R. Desgrand - 69625 Villeurbanne CEDEX - France
Tel.: +33 4 72 66 20 70 - Fax: +33 4 72 39 08 65
E-Mail: contact@coelme-egic.com, www.coelme-egic.com
f @ in

