

**SLOB 72.5-550 kV Double-motion vertical-break disconnectors**

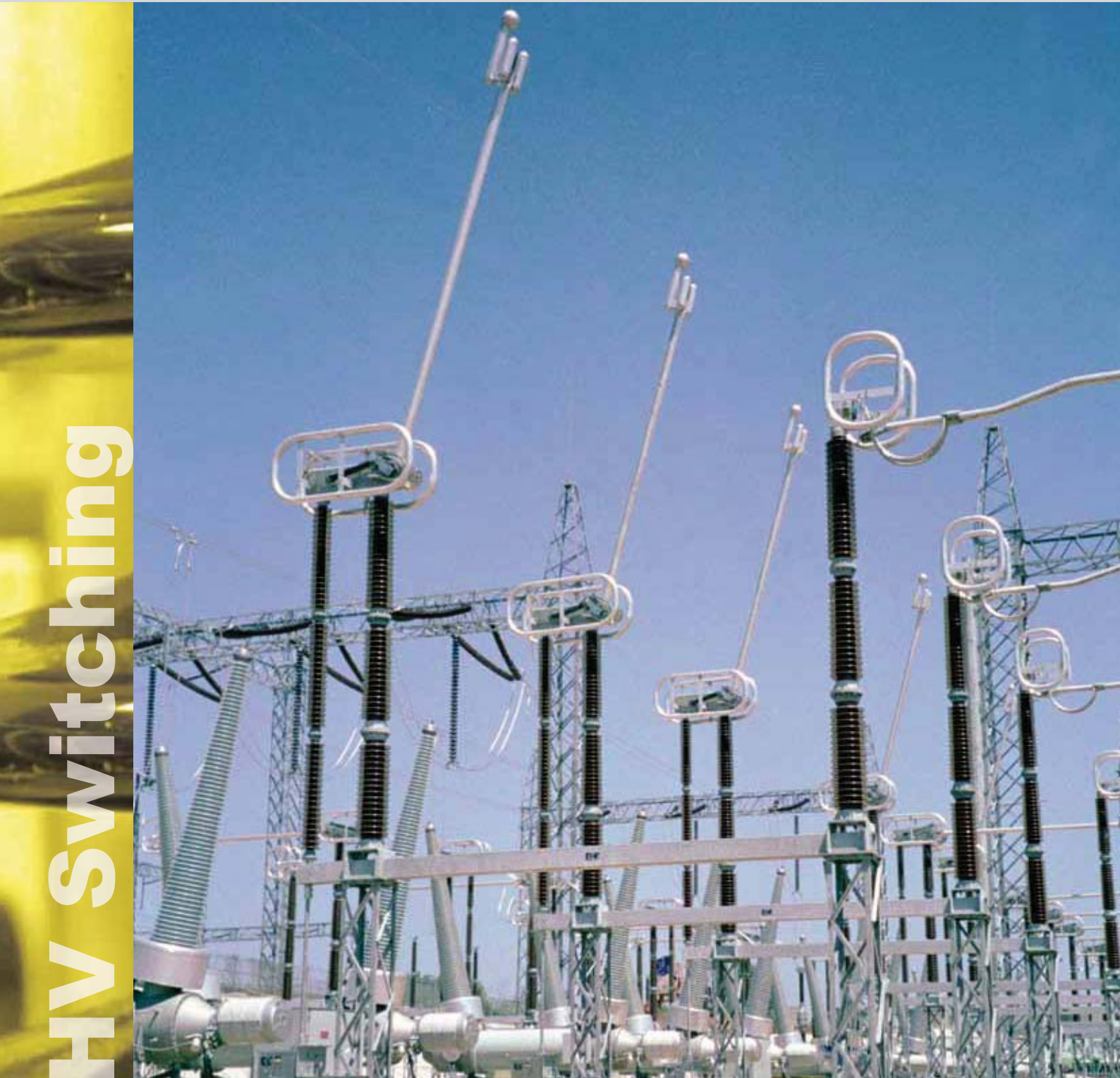

**HV Switching**

## We know how

Our range of vertical-break disconnectors is designed to ensure the best performances and reliability, which are the result of our 70-year old experience. Over 100,000 disconnectors installed in more than 100 countries worldwide are the guarantee of best-buys.



## The SLOB vertical-break disconnector

The SLOB vertical-break disconnector is formed by three poles, operated simultaneously either by a single operating mechanism and mechanical linkages between the poles or by one mechanism for each pole.

Due to the vertical motion of its main blade, the SLOB disconnector features very short clearance between phases, allowing space saving in bay design. The insulators, directly bolted on the base frame ensure a good withstand to terminal loads and can comply with either IEC or ANSI standard. Special heights and creepage distances are also available on request.

To adapt to various layouts of substations, the poles can be erected traditionally (horizontal) or wall-mounted, and even upside down.

Like all our models, the SLOB meets the latest international standards (IEC, ANSI) but can also be customised according to particular specification.



## Earthing switch

Integrated earthing switches are available for mounting at each or both sides of the pole, with the same short-time current withstand capability.

The earthing switch is actuated by the same types of operating mechanisms as the disconnector, either manually or electrically, single-pole or 3-pole operation. It can be electrically and/or mechanically interlocked with the main blade.



## Construction features

The current path is made of welded and drawn aluminium parts, with silver plated copper contacts. Flexible aluminium straps ensure the connection between the upper frame and the rotary arm. All the hardware of the live part is made of stainless steel.

The upper frame consists in welded aluminium plates, supporting the hinges and the balancing spring. Due to the aluminium straps, the current path between the arm and the upper frame is permanent and can not be cut by external factors, like it could be if this path were established only in the closed position.

Both male and female contacts are silver plated (thickness according to rated current) and protected from corona effects by suitable corona shields, according to rated voltage. The male (moving) contact is bolted on a round aluminium tube.

The female (fixed) contact is of the reverse-loop type, to guarantee the best withstand to short-time currents: the higher is the current, the higher the contact pressure is. The static contact pressure is ensured by stainless steel springs. Furthermore, due to its exclusive kinematics, the mobile contact is locked in the fixed contact, preventing any discontinuity due to electrodynamic or other mechanical force.

The base frame and the rotary support are made of hot-dip galvanised steel profiles. The bearings are sealed and greased for a lifetime of maintenance free operation

All our design and manufacturing process is ruled by ISO 9001 certified procedures to guarantee a perfect repetitivity of the performances from the type-testing to the delivery of series.



## Operating principle

The base frame supports two insulators and a rotating insulating rod (drive insulator), which allows to transfer the motion to the moving contact

The live part consists in a rotary blade, with the moving contact bolted at its end, and a fixed contact. The fixed contact ① (female) is bolted on the top of the insulator and receives the moving one ② (male), which rotates and travels from the open position to the fully closed position, according to the working principle shown in the opposite figure. The power chain goes through the insulating rod ③, the crank-lever system ④ and finally to the arm ⑤. For a smooth and low power-demanding motion, the rotary blade weight is balanced by springs. The corona rings avoid radio-interference by canceling corona effect according to IEC / CISPR and NEMA standards.

The HV terminals ⑤ are of the IEC flat type. ANSI or custom terminals are also available upon request.

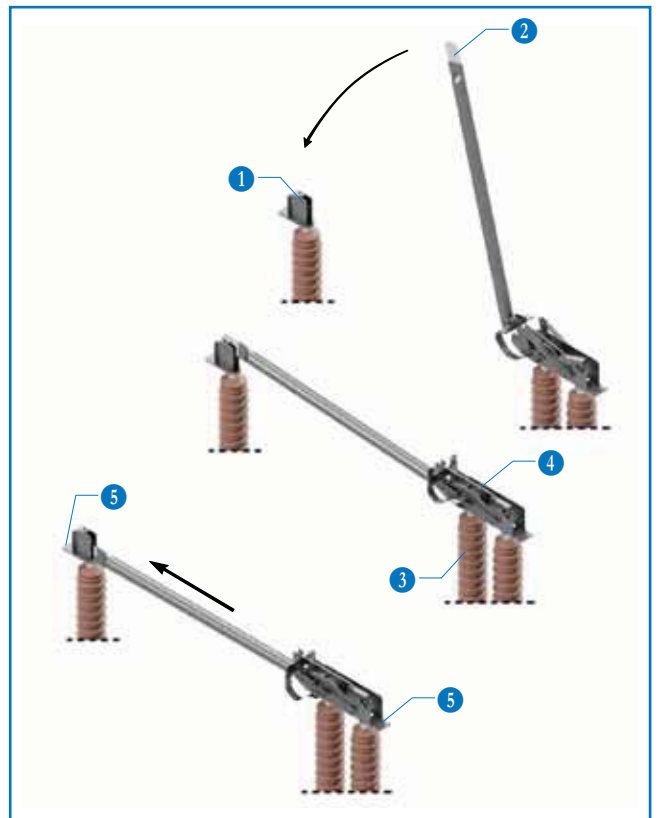

## Ratings and dimensions

The values in the table refer to IEC standards, unless explicit reference to ANSI is made; for missing ANSI ratings, refer to C37.32

Rated voltage	$U_r$ (kV)	72.5	123	145	170	245	300	362	420	550	
Rated power-frequency withstand voltage	TE $U_d$ (kV)	140	230	275	325	395	460	380	450	520	620
	AID $U_d$ (kV)	160	265	315	375	460	530	435	520	610	800
Rated lightning impulse withstand voltage	TE $U_p$ (kV <sub>p</sub> )	325 (IEC) 350 (ANSI)	550	650	750	950 (IEC) 900 (ANSI)	1050	1050	1175	1425	1550
	AID $U_p$ (kV <sub>p</sub> )	375	630	750	860	1050	1200	1050 (+170)	1175 (+205)	1425 (+240)	1550 (+315)
Rated switching impulse withstand voltage	TE $U_s$ (kV <sub>p</sub> )	-	-	-	-	-	-	850	950	1050	1175
	AID $U_s$ (kV <sub>p</sub> )	-	-	-	-	-	-	700 (+245)	800 (+295)	900 (+345)	900 (+450)
TE: To Earth AID: Across the Isolating Distance											
Rated continuous current	$I_r$ (A)	up to 6300 IEC / ANSI (depending on rated voltage)									
Rated short-time withstand current	$I_k$ (kA)	up to 75 / 3s (depending on rated current)									
Rated peak withstand current	$I_p$ (kA <sub>p</sub> )	up to 190 (depending on rated current)									
Dimensions (mm)	A	1100	1600	2100	2100	2900	3200	3200	3700	4200	5000
B	IEC	770	1220	1500	1700	2100	2300	2300	2900	3350	3650
	ANSI	762	1143	1372	1575	2032	2337	2337	3099	-	3861
C	IEC	977	1427	1727	1927	2357	2557	2557	3157	3657	3957
	ANSI	969	1350	1599	1802	2289	2594	2594	3406	-	4168
D		550	550	550	550	550	550	550	550	700	700
E	IEC	2400	3305	4060	4260	5510	6000	6000	7080	8170	9330
	ANSI	2390	3225	3930	4120	5410	6035	6035	7280	-	9540
F		1300	1800	2300	2300	2660	2960	2960	3460	3930	4730
G		-	-	-	-	240	240	240	240	270	270
H		240	240	240	240	270	270	270	270	340	340
J		4 ø18	4 ø18	4 ø18	4 ø18	8 ø18	8 ø18	8 ø18	8 ø18	8 ø22	8 ø22

## Reliability and maintenance

Due to lifetime greased or self-lubricated hinges, and self-wiping contact, the maintenance of the SLOB metallic parts is ensured by its own motion.

The use of corrosion-free or protected materials for all the components induces an exceptional reliability over many years of service. The mechanical endurance performance exceeds the IEC standard.

## Optional devices

Upon request, the disconnecter can be equipped with a bus-transfer current switching device, according to IEC 62271-102 (annex B).

The integrated earthing switch can also be fitted with an optional induced currents switching device, as per IEC 62271-102 (annex C).

For operation under severe ice conditions (up to 20 mm), ice shields are available to protect the parts, where needed.

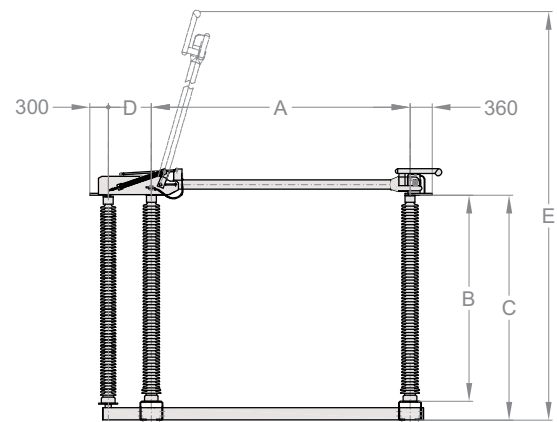

1250-2500A

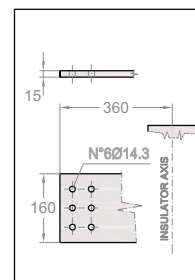

3150-4000A

