

VSD 72.5-245 kV Load-break switcher



HV Switching

We know how

Our range of switchers is designed to ensure the best performances and reliability, which are the result of our 70-year old experience in the field of high voltage.

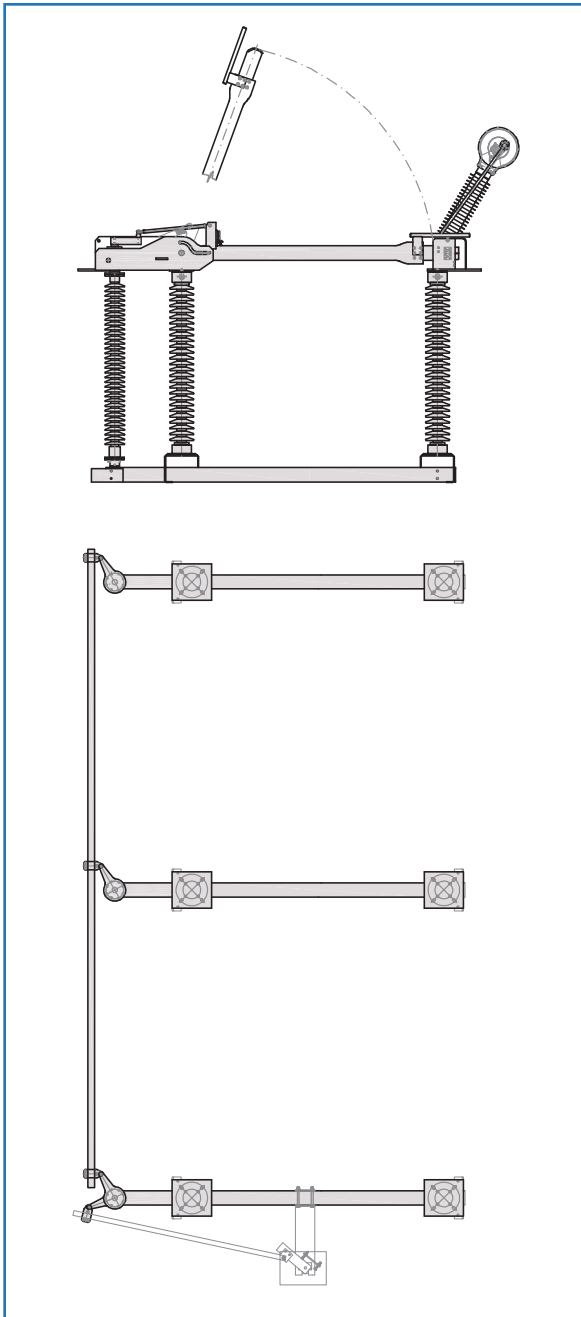

The VSD load-break switcher

The VSD is an outdoor switch-disconnector. It is composed of an SF₆ interrupter (called "LLS[®]") and a vertical-break disconnector.

The addition of the interrupter gives reliable and cost-effective mainly active load, line closed-loop and line-charging breaking capability to the disconnector and the special design of the equipment eliminates any concern about switching sequence errors.

When the disconnector is open, the position of its arm gives the visual evidence of circuit interruption, thus enhancing personnel safety; when it is closed, current never flows through the LLS[®].

The VSD is the only vertical switch-disconnector with single gap SF₆ interrupter from 72.5 kV up to 245 kV. Its versatility allows it to be mounted either horizontally or vertically and also in phase-over-phase configuration.

Like all our models, the VSD meets the latest international standards (IEC, ANSI) and it can also be customised according to clients' particular specifications.



Earthing switch

Integrated earthing blades are available for mounting on each pole, with the same short-time current withstand capability as the main blades.

The earthing switch is actuated by the same types of operating mechanisms as the disconnector, either manually or electrically, either single- or 3-pole. It can be electrically and/or mechanically interlocked with the main switch.

Construction features

The main circuit of each pole consists of a moving arm, a fixed contact and an SF₆ interrupter (LLS®).

The moving arm is made of an aluminium alloy tube which carries, at its end, the moving contact and the "limit-stop" of the blade; the moving contact is made of a copper flat bar suitably shaped for the correct engagement with the fixed contact; for higher voltage ratings, the "limit-stop" also acts as a corona shield.

The moving arm is hinged, at the other end, to an aluminium alloy welded support, which includes one of the two HV terminals of the main circuit; flexible aluminium straps ensure the connection between the moving arm and its support.

The fixed contact consists of an aluminium alloy welded support, which includes the other HV terminal; copper fingers, whose number and dimensions depend on the rated current, are bolted to the support; the contact pressure is assured by stainless steel springs. Copper contacts are silver plated, with silver thickness depending on the rated current; they are self-cleaning and are suitably designed for withstanding considerable short-circuit stresses.

The LLS® consists of a single-break SF₆ interrupter, contained inside a composite insulator, made of a fiberglass tube with silicone sheds and aluminium alloy fittings; the interrupter is operated by a spring mechanism placed at the top of the composite insulator; the spring mechanism is activated by an operating bar made of copper. The base-frame of each pole, which is provided with a rotary support, is made of hot-dip galvanised steel; its bearings are sealed and guaranteed to ensure maintenance-free operation for the whole life of the equipment.

The transmission system consists of a set of shafts, rods and levers, made of hot-dip galvanised steel and suitably linked to each other to transmit the power from the operating mechanism to the rotary supports of base-frames.

The whole design and manufacturing process is ruled by ISO 9001 certified procedures, to guarantee perfect performance reproducibility from type-testing to series production.



Operating principle

The base-frame supports two post insulators ① and one rotating insulating rod ② (driving insulator) which allows to transfer the motion of the operating mechanism to the main circuit.

During the opening operation, the moving arm of disconnector ③ picks up and lifts the interrupter operating bar ④.

The lifting of the operating bar activates the spring mechanism ⑤ that opens the main contacts of the interrupter ⑥.

After that, while continuing its upward movement, the disconnector arm releases the operating bar, that falls down and resets (closes) the main contacts of the interrupter.

The arm continues the opening operation until it reaches the fully open position; in this position, the moving arm forms an angle of about 16°-24° (depending on the rated voltage) with the vertical axis.

During the closing operation, the moving arm moves downwards, until it gets in touch with the fixed contact ⑦; then, a further rotation of the driving insulator, makes the arm move horizontally, along its longitudinal axis, and insert the moving contact ⑧ into the "fingers" of the fixed one.

The HV terminals ⑨ are as shown in the next page figure; customised terminals are also available upon request.

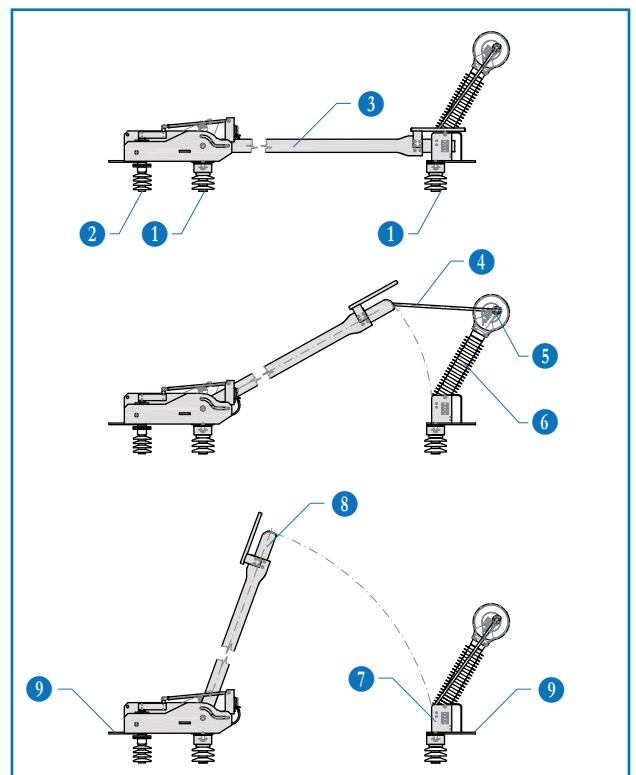

Ratings and dimensions

The values in the table refer to IEC standards, unless explicit reference to ANSI is made; for missing ANSI ratings, refer to C37.32

Rated voltage	U_r (kV)	72.5	123	145	170	245	
Rated power-frequency withstand voltage	TE U_d (kV)	140	230	275	325	395	460
	AID U_d (kV)	160	265	315	375	460	530
Rated lightning impulse withstand voltage	TE U_p (kV _p)	325 (IEC) 350 (ANSI)	550	650	750	950 (IEC) 900 (ANSI)	1050
	AID U_p (kV _p)	375	630	750	860	1050	1200

TE: To Earth,
AID: Across the Isolating Distance

Rated continuous current	I_r (A)	up to 3150 IEC / ANSI (depending on rated voltage)					
Rated short-time withstand current	I_k (kA)	up to 63 / 3s (depending on rated current)					
Rated peak withstand current	I_p (kA _p)	up to 160 (depending on rated current)					
Rated mainly active load breaking current	I_l (A)	up to 3150 (depending on rated current)					
Rated line-charging breaking current	I_{4b} (A)	up to 300 (depending on rated current)					
Rated transmission line closed-loop breaking current	I_{2a} (A)	up to 3150 (depending on rated current)					
Ambient temperature range	(°C)	up to -40/+50					
Minimum mechanical and electrical endurance	(cycles)	2000					

Dimensions (mm)	A		1100	1600	2100	2100	2900	3200
B	IEC		770	1220	1500	1700	2100	2300
	ANSI		762	1143	1372	1575	2032	2337
C	IEC		977	1427	1727	1927	2357	2557
	ANSI		969	1350	1599	1802	2289	2594
D	IEC		2400	3305	4060	4260	5510	6000
	ANSI		2390	3225	3930	4120	5410	6035
E			1300	1800	2300	2300	2660	2960
F			-	-	-	-	240	240
G			240	240	240	240	270	270
H			4 ø18	4 ø18	4 ø18	4 ø18	8 ø18	8 ø18

Reliability and maintenance

Due to lifetime greased (or self-lubricated) hinges and to self-wiping contacts, the maintenance of the VSD is ensured by its motion.

The use of corrosion-free (or coated) materials for all components ensures exceptional reliability for many years of service.

The mechanical endurance performance exceeds IEC standard requirements.

Optional features

The VSD is only one of the possible combinations of the LLS® with disconnectors.

As a matter of fact, we can also provide combinations of horizontal interrupters with centre- or side-break disconnectors and special combinations with vertical interrupters.

As the LLS® adapts to most other manufacturer's disconnectors, we can provide it with the suitable adaptation kit, even for field retrofit.

