

CSH and CSH-VB 72.5-245 kV Circuit switcher

HV Switching



We know how

Our range of switchers is designed to ensure the best performances and reliability, which are the result of our 70-year old experience in the field of high voltage.



The CSH / CSH-VB circuit switcher

The CSH switcher is made of three poles, operated simultaneously by a single operating mechanism. Pole simultaneity is achieved through the use of shunt trips on opening, and through mechanical interphase linkages on closing.

It is available in two versions:

- The type CSH is the non-blade model, without built-in disconnector;
- The type CSH-VB includes a vertical-break disconnector, mounted in series, and synchronised with the chamber.

Both versions use the same SF₆ chamber, that is used to make and break on rated current, but also in fault condition. The CSH-VB adds the appreciable feature of visible isolation in air.

Like all our models, the CSH meets the latest international standards (IEC, ANSI) and can be fitted with both types of insulators, but can also be customised according to particular specification.

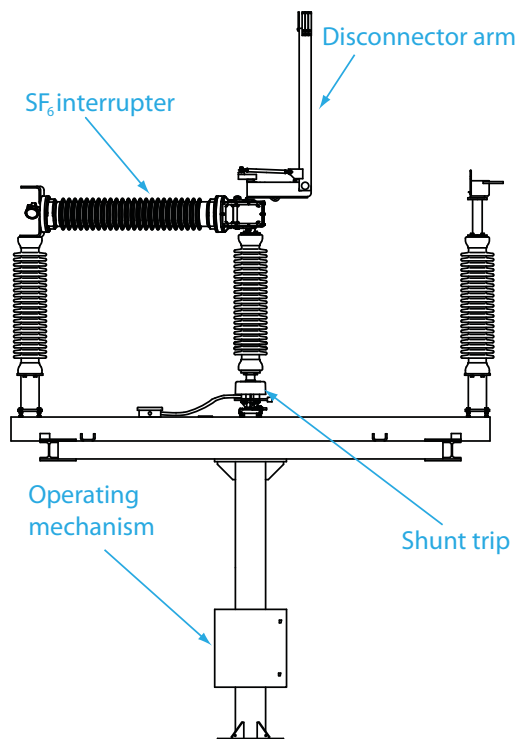

Key features and applications

The CSH and CSH-VB provide a versatile, space saving solution for fault protection and switching where rapid reclosing of the circuit is not desirable. They allow to switch:

- Transformers
- Reactors
- Lines
- Cables

The single gap SF₆ chamber needs no grading capacitor to maintain insulation, and is able to break the fault current within 5 to 6 cycles, depending on the voltage, and the power frequency. Compared to systems making in the air, this produces very few disturbances on the system.

The CSH-VB offers the unique feature of combining SF₆ making and breaking with visible gap air insulation, in a single switching sequence and through a single operating mechanism. Therefore, no additional interlocking is necessary between switching and isolating devices, and both the reliability and the compactness of the bay are improved.

Like for any of our disconnectors, it is possible to fit 1 or 2 earthing switches on the CSH-VB, and even instrument transformers, to get a full, free-standing bay switchgear assembly.

Construction features

Each pole of CSH has one fixed insulator, and one rotary insulator that actuates the chamber. The CSH-VB adds one fixed insulator to support the fixed contact of the disconnecter.

The chamber is a single-gap, puffer type, using SF₆ gas. It is housed in a horizontal hollow porcelain insulator. Its motion is made through purely mechanical means:

- Energy storage is made through opening and closing springs, housed in an aluminium casting located on top of the insulating rod.
- A shunt trip, located at the base of the rotary column, initiates the tripping operation, in the opening phase.
- The CSH / CSH-VB is operated through a single disconnector-type operating mechanism, supplying the necessary torque to charge the interrupter, and to operate the disconnector for the CSH-VB.

All conductive parts are made of copper or aluminium, and assembled with stainless steel hardware, while the contacts are made of solid copper, with silver plating where necessary. The HV terminals are made of aluminium.

The base frame and the rotary support are made of hot-dip galvanised steel profiles. The bearings are sealed and greased for a lifetime of maintenance free operation.

All our design and manufacturing process is ruled by ISO 9001 certified procedures to guarantee a perfect repeatability of the performances from the type-testing to the delivery of series.

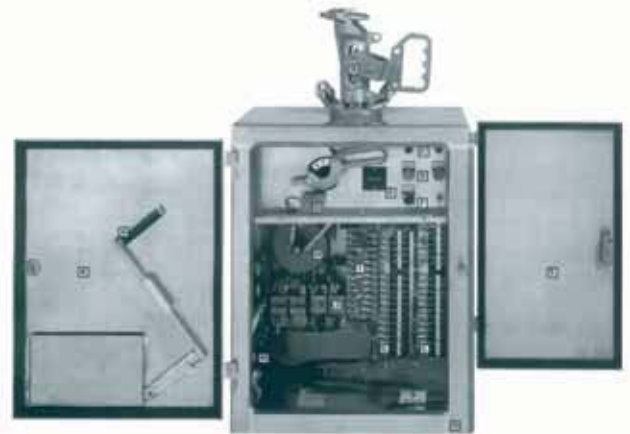

Operating principle

From the fully closed position ① (both interrupter and DS are closed), a 12° rotation of the central insulator, initiated by the shunt trip or manual or motor operation, releases the opening springs in the driver mechanism, resulting in high speed opening ② of the interrupter contacts, which allows to break the rated or fault current of the circuit.

After the interrupter has been fully opened ③ an additional 114° of rotation fully opens the disconnector. Upon reaching the full open blade position ④, the driver mechanism is reset for a closing sequence. Charging of the shunt trip occurs during the last 12° of opening rotation.

The closing sequence happens exactly in the reverse order: the rotation of the central insulator results in blade travel and charging of the interrupter closing springs in the driver mechanism.

The closing springs are released with the last few degrees of insulator rotation, closing the interrupter and charging the opening springs, while the disconnector is already fully closed, thus, able to withstand the fault current of the circuit. Making the circuit in SF₆ prevents any damage on disconnector contacts.

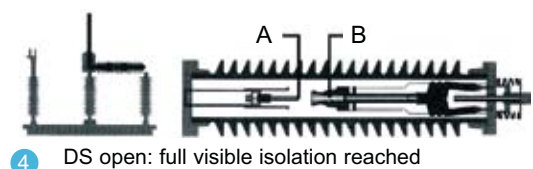
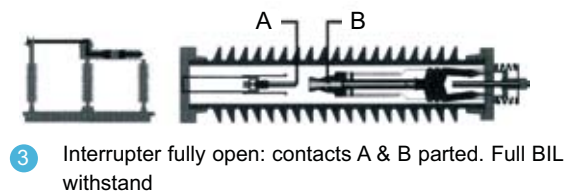
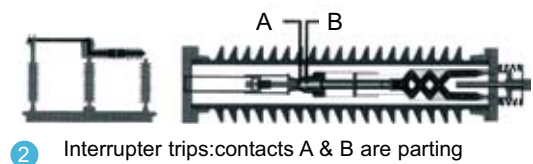
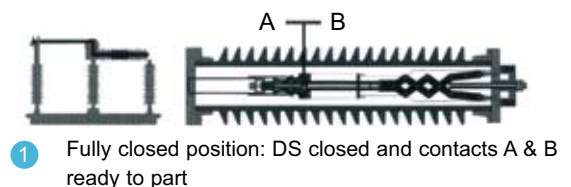

Ratings and dimensions

The values in the table refer to IEC standards, unless explicit reference to ANSI is made; for missing ANSI ratings, refer to C37.32

Rated voltage		U_r (kV)	72.5	123	145	170	245	
Rated power-frequency withstand voltage	TE	U_d (kV)	140	230	275	325	395	460
	AID	U_d (kV)	160	265	315	375	460	530
Rated lightning impulse withstand voltage	TE	U_p (kV _p)	325 (IEC) 350 (ANSI)	550	650	750	950 (IEC) 900 (ANSI)	1050
	Int.	U_p (kV _p)	350	550	650	750	900	900
	AID	U_p (kV _p)	375	630	750	860	1050	1200

TE: To Earth, INT: Interrupter BIL

AID: Across the Isolating Distance: insulation guaranteed by the DS

Rated continuous current	I_r (A)	up to 2000 IEC / ANSI (depending on rated voltage)	
Rated short-circuit breaking current	I_{sc} (kA)	up to 40 (depending on rated current)	20
Interrupting time	(cycles)	4-5	5-6
Rated short-circuit making current	I_{ma} (kA _p)	up to 40 / 100 peak (depending on rated current)	
Rated short-time withstand current	I_k (kA)	up to 40 / 3s (depending on rated current)	
Rated peak withstand current	I_p (kA _p)	up to 100 (depending on rated current)	

Dimensions (mm)	A		1457	1457	1842	1842	2070	2070
	B ₁		3131	3616	4116	4316	4813	5331
	B ₂		1762	1762	2146	2146	2375	-
	C		1420	1905	2020	2220	2438	2956
	D	IEC	770	1200	1500	1700	2100	2300
		ANSI	762	1143	1372	1575	2032	-
	E	IEC	1757	2187	2487	2687	3087	3287
		ANSI	1749	2130	2359	2562	3019	-
	F		980	1465	1575	1775	2753	3270
	G ₁		3063	3548	4048	4248	4689	5207
	G ₂		1727	1727	2111	2111	2340	-

Reliability and maintenance

Due to lifetime greased or self-lubricated hinges, and self-wiping contacts, the maintenance of the CSH metallic parts is ensured by its own motion. The use of corrosion-free or protected materials for all the components induces an exceptional reliability over many years of service. The mechanical endurance performance exceeds the IEC standard requirements.

Custom applications

The CSH / CSH-VB is only one of the possible combinations of our special breakers with disconnectors. Depending on the application, we can also provide combinations of horizontal chambers with Centre-break or Double-break disconnectors, or even similar combinations with vertical chambers.

Upon request, extended ratings on current making / breaking are also available.

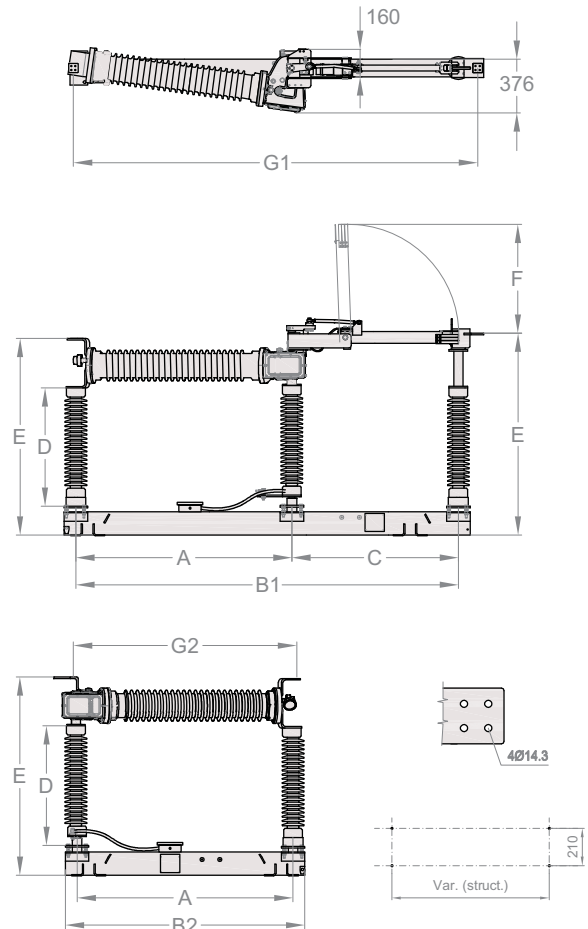

COELME

Via G. Galilei, 1/2 - 30036 Santa Maria di Sala (VE) - Italia
Tel.: +39 041 486022 - Fax: +39 041 486909
E-Mail: contact@coelme-egic.com, www.coelme-egic.com



EGIC

60b, rue L. et R. Desgrand - 69625 Villeurbanne CEDEX - France
Tel.: +33 4 72 66 20 70 - Fax: +33 4 72 39 08 65
E-Mail: contact@coelme-egic.com, www.coelme-egic.com

